

TODAY'S SOLUTIONS for tomorrow's risks

COLD STORAGE WAREHOUSE FIRE PROTECTION SOLUTION

Installed with a suitable fire detection system, this fire extinguishing method is proven to be safe for humans, causes no loss to products and the gas does not damage the ozone layer - making it very effective for cold storage facilities.



FIRE PROTECTION CHALLENGES

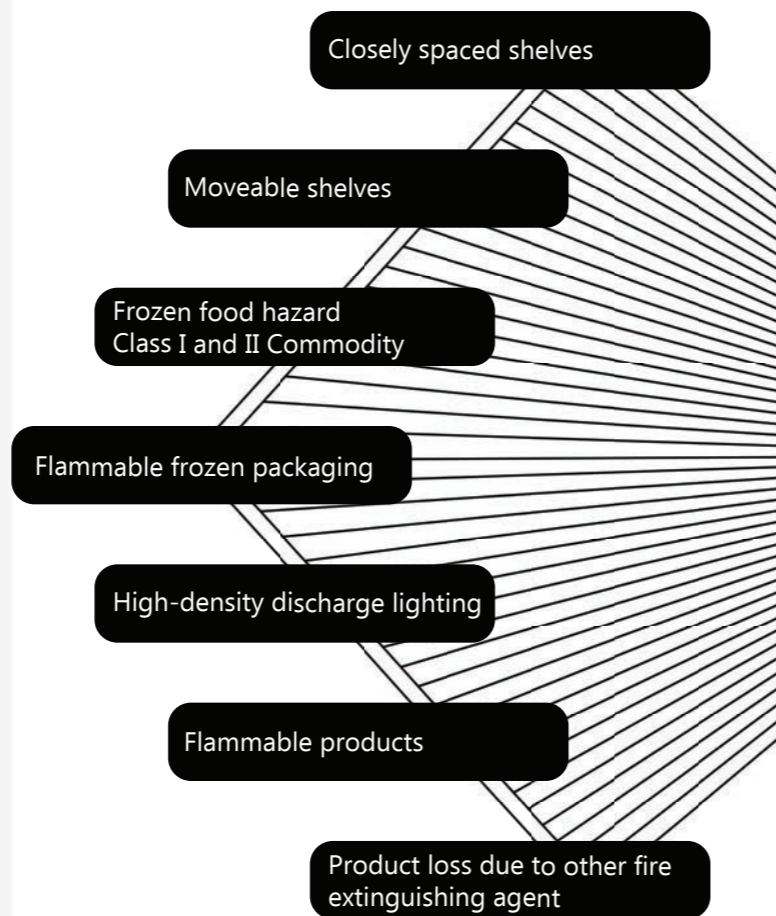

WHAT IS INERGEN GAS

A natural and unique fire extinguishing gas blend, which contains no hazardous chemicals, is known as the green alternative, which is thus environmentally friendly.

INERGEN GASEOUS IG-541 FIRE EXTINGUISHING SYSTEM

Cold Storage Warehouse Facility Installations



INERGEN GASEOUS FIRE SUPPRESSION SYSTEM ADVANTAGES

-  No facility size restrictions - Multiple Zones
-  No Restriction to rack heights or rack mobility
-  Lower refill costs
-  Mechanically tested without refilling the cylinders
-  No influence on change of racks / supply chain
-  Easy valve removal from cylinder for service
-  No damage to products, facility or ISO wall
-  No hazardous environments upon discharge

*Subject to Change without prior notice.
All issues are UNCONTROLLED Copies.
(Rev01)*

ODOUR FREE CHEMICALS FREE WATER FREE

Head Office

Unit 7, Flintstone Park, Gateway Industrial Estate 42 Sarel Baard Rd, Centurion 0157, South Africa PO Box 277, Raslouw 0109, South Africa

Tel: +27 12 621 9400
Fax: +27 12 661 6110

info@fstafira.co.za
www.fstafira.co.za



FIRE EATER

HOW DOES INGERGEN GAS WORK

Inergen works by flooding the protected area with an agent consisting of specific combination of Argon, Nitrogen and Carbon Dioxide.

Inergen is stored in 300bar high pressure cylinders. Inergen extinguishes the fire by reducing the oxygen levels in the risk area to below 15%, where combustion will no longer be sustained.

The added Co2 will stimulate the respiratory system of anyone remaining in the discharge area and reducing the risk of hypoxia.



SELECTOR VALVES

Inergen Gaseous Fire Extinguishing System, with our seamless technology, cuts down the capital costs of the system. It also increases redundancy and protection of your valuable assets by offering main and reserve with automatic resetting selector valves.

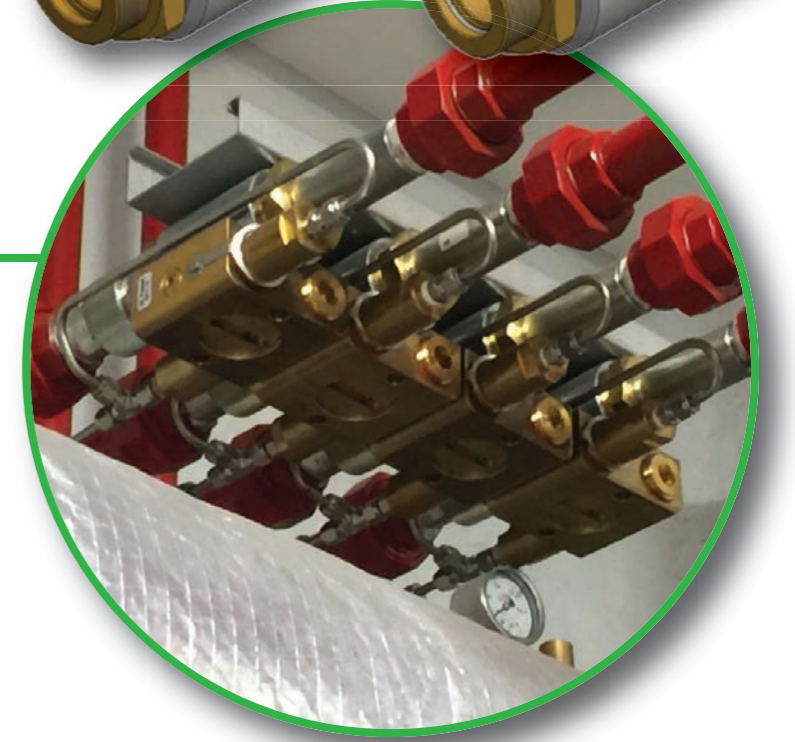
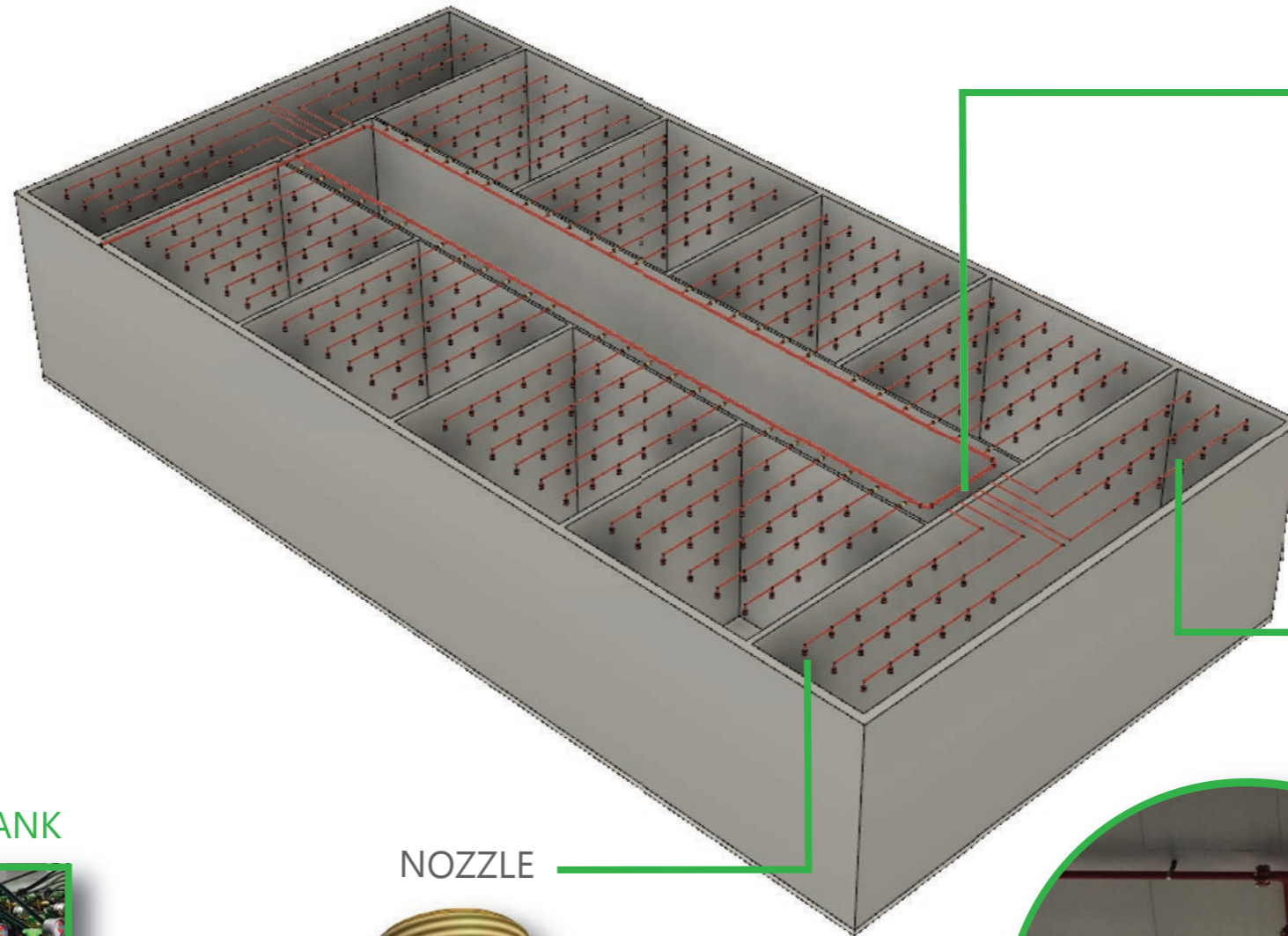
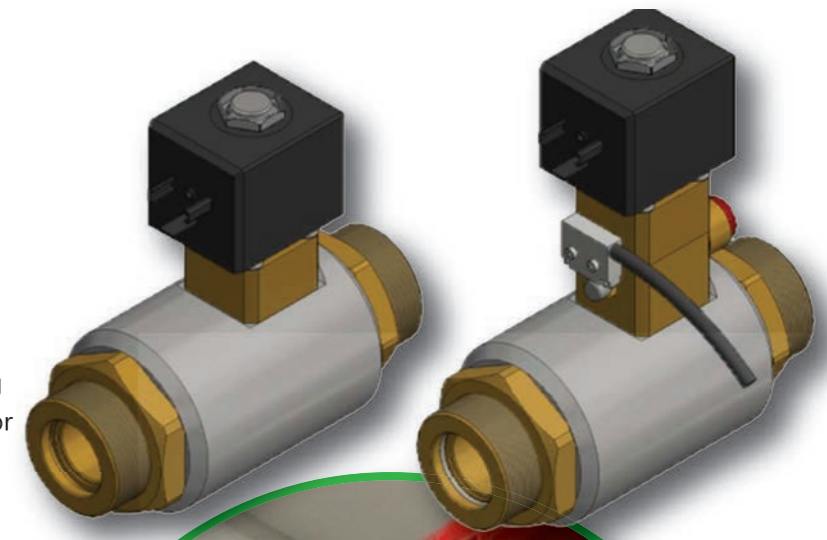

PIPE WORK



DISTRIBUTED SYSTEM CENTRALISED BANK



NOZZLE

